

## Blum MOVENTO Concealed Runner

### MOVENTO: The concealed runner system

MOVENTO offers a synchronised feather-light glide, with 4-dimensional front adjustment and dynamic carrying capacities of 40 and 60 kg.

MOVENTO is suitable for use with either SERVO-DRIVE or TIP-ON for handle-free fronts.

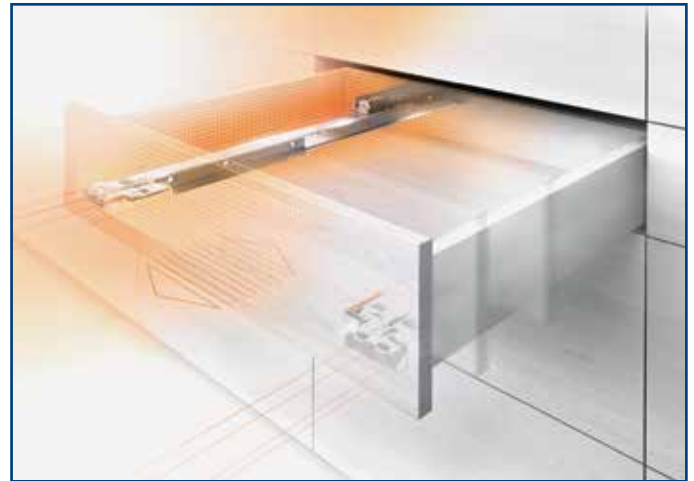

Blumotion



Synchronised glide



Easy assembly

### New 4-dimensional front adjustment

4-dimensional front adjustment means that you not only have tried and tested height and tilt adjustment, but also new side and depth adjustment. Adjustments are all tool free, precise and easy.



1. Side adjustment : Carried out via the locking device



2. Rear side adjustment



3. Tilt adjustment



4. Height adjustment

## Blum MOVENTO with BLUMOTION

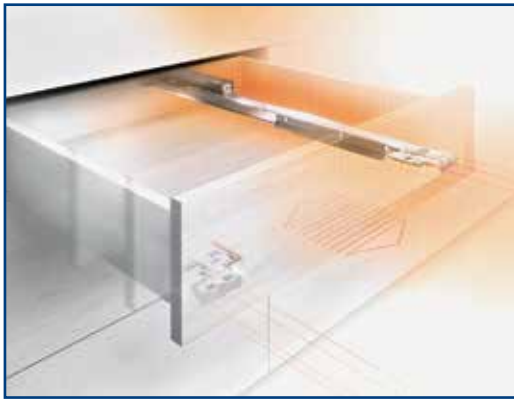

- Concealed, guided, full extension
- Integrated BLUMOTION soft close
- Low opening force to optimise running action
- 4 dimensional tool-free adjustment
- Synchronised smooth running action
- Unparalleled running action for the lifetime of the furniture
- 40kg weight carrying capacity 270 - 600 mm
- 60kg weight carrying capacity 450 - 750 mm

### Space Requirement

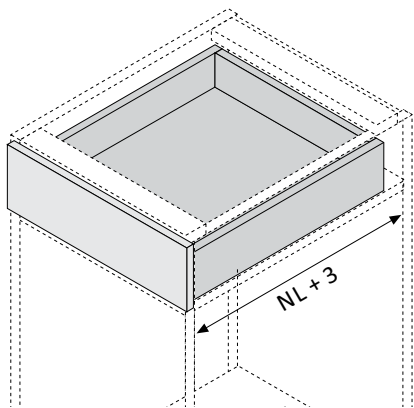

### Components

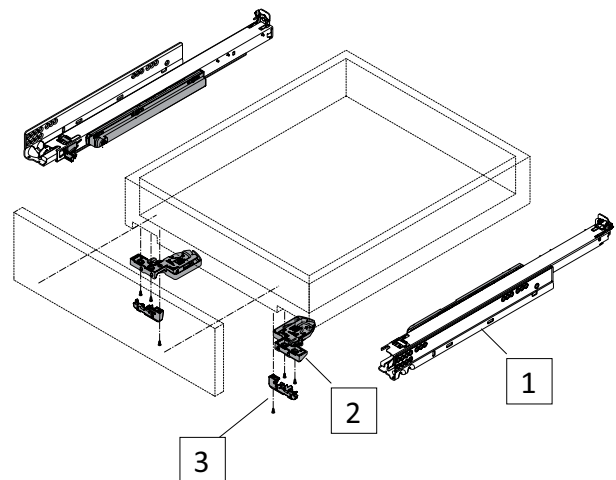

1. Runners
2. Locking Device
3. Depth adjuster (Optional)

### Height Requirement

\* If runners are fitted prior to cabinet assembly increase height by 1 mm to allow for tolerances

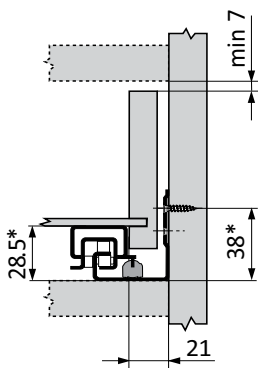

IDW = Internal drawer width  
ICW = Inner cabinet width

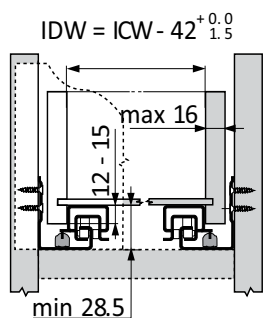

DL = Drawer Length  
NL = Nominal Length

\* + an extra 12 mm if side stabiliser is used

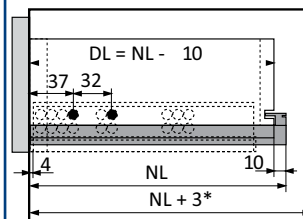

IDL = Inner Drawer Length

DL = Drawer Length  
NL = Nominal Length  
X = Drawer Front  
\* + extra 4 mm TIP-ON  
\* + extra 3 mm with depth adjustment

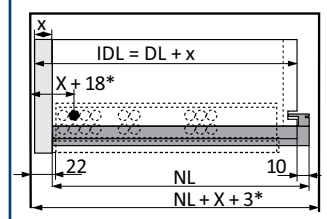

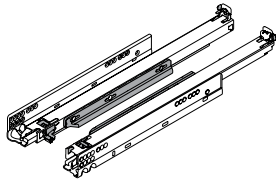

Note: For runner positions and further technical information see Page 1.80

### MOVENTO Runner Set



1

Runner Length	40 kg	60 Kg	P.U
270 mm	B760H270B		6
350 mm	B760H350B		6
400 mm	B760H400B		6
450 mm	B760H450B	B766H450B	6
500 mm	B760H500B	B766H500B	6
550 mm	B760H550B	B766H550B	6
600 mm	B760H600B 	B766H600B	6
650 mm	-	B766H650B	6
700 mm	-	B766H700B 	6
750 mm	-	B766H750B 	6

### MOVENTO Locking Device with Side Adjustment

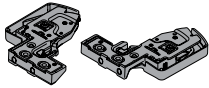

2

Fixing Method	Left Hand	Right Hand	P.U
Screw On	BT517601L	BT517601R	250

### MOVENTO Depth Adjuster (Optional for Internal Drawers)

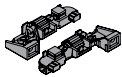

3

Fixing Method	Art. No.	P.U
Screw On	B2987600	250

### MOVENTO Side Stabilisation Kit (Optional)



Drawer Length	Art. No.	P.U
≤ 750 mm	BZS7750MU 	10

For cabinet widths ≤ 1400mm for Cutting to size: Internal cabinet width -295 mm  
 Runner length 400 - 750 mm recommended for cabinet widths ≥ 900 mm  
 Runner length 270 - 350 mm recommended for cabinet widths ≥ 600 mm

### Back fixing bracket for MOVENTO / TANDEM (Optional)

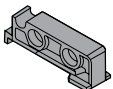

Fixing Method	Art. No.	P.U
Screw On	BT517000.01 	10

For pull out shelves or where no hole is drilled in the back of drawer.  
 Used Left and right, reduce the drawer side depth by an additional 10 mm

### Pull Out Shelf Lock (Optional) See Page 1.84



Fixing Method	Art. No.	P.U
Screw On	B295H5700	1

### Pull Out Shelf Lock Synchronisation Shaft (Optional) See Page 1.84

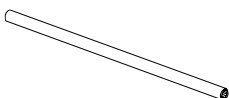

Fixing Method	Art. No.	P.U
Tool Free	BZST1160W	1/40

## Blum MOVENTO with TIP-ON BLUMOTION



- Concealed, guided, full extension
- Integrated BLUMOTION soft close
- Touch to open
- Low opening force to optimise running action
- 4 dimensional tool-free adjustment
- Synchronised smooth running action
- Compatible with side stabilisation for MOVENTO
- Unparalleled running action for the lifetime of the furniture
- 40kg weight carrying capacity 270 - 600 mm
- 60kg weight carrying capacity 450 - 750 mm

### Space Requirement

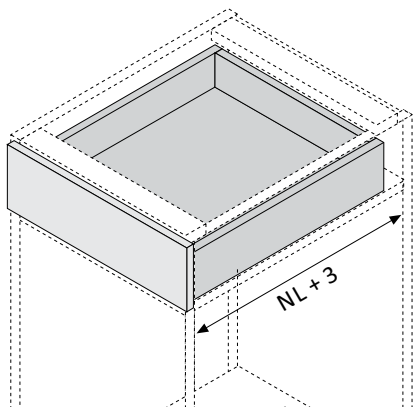

### Components

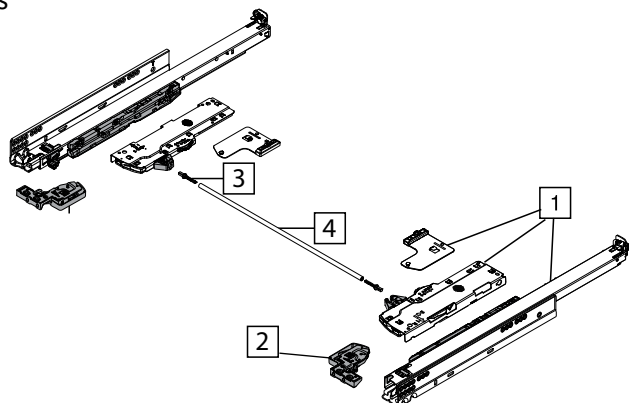

1. Runners, TIP-ON BLUMOTION mechanisms
2. Locking Device
3. Synchronisation adaptors
4. Synchronisation rods

### Height Requirement

\* If runners are fitted prior to cabinet assembly increase height by 1 mm to allow for tolerances

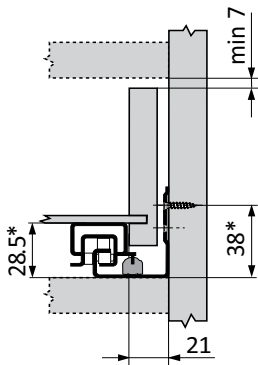

IDW = Internal drawer width  
ICW = Inner cabinet width

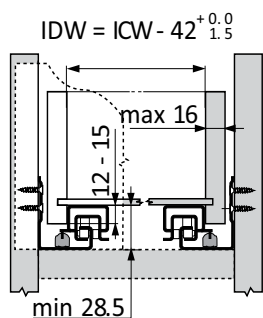

DL = Drawer Length  
NL = Nominal Length

\* + an extra 12 mm if side stabiliser is used

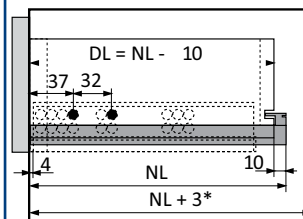

IDL = Inner Drawer Length

DL = Drawer Length  
NL = Nominal Length  
X = Drawer Front  
\* + extra 4 mm TIP-ON  
\* + extra 3 mm with depth adjustment

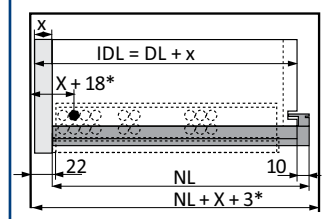

Note: For runner positions and further technical information see Page 1.119

## Blum MOVENTO with TIP-ON BLUMOTION

### MOVENTO TIP-ON BLUMOTION

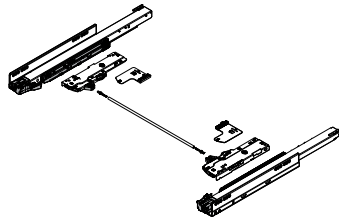
**1**

Nominal Length	Weight Capacity	Code	Unit Included*	Alternative Unit	Alternative Code	P.U
270 mm	40	B760H270TB	≤ 10 kg	10 - 20 kg	B60L7140	1 set
350 mm	40	B760H350TB	≤ 20 kg	15 - 40 kg	B60L7540	
400 mm	40	B760H400TB	≤ 20 kg			
450 mm	40	B760H450TB	15 - 40 kg	≤ 20 kg	B60L7340	
500 mm	40	B760H500TB	15 - 40 kg	≤ 20 kg		
550 mm	40	B760H550TB	15 - 40 kg	≤ 20 kg		
600 mm	40	B760H600TB	15 - 40 kg	≤ 20 kg		
450 mm	60	B766H450TB	35 - 60 kg	N/A		
500 mm	60	B766H500TB	35 - 60 kg			
550 mm	60	B766H550TB	35 - 60 kg			
600 mm	60	B766H600TB	35 - 60 kg			
650 mm	60	B766H650TB	35 - 60 kg			
700 mm	60	B766H700TB	35 - 60 kg			
750 mm	60	B766H750TB	35 - 60 kg			

\* The TIP-ON BLUMOTION Unit Included is based on most likely application, weights will vary based on timber used, drawer heights and widths, if the performance is not optimum, please switch to an alternative set.

### MOVENTO Locking Device with Side Adjustment

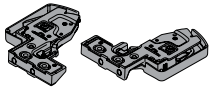
**2**

Fixing Method	Left Hand	Right Hand	P.U
Screw On	BT517601L	BT517601R	250

### End Brackets for Synchronisation Rods

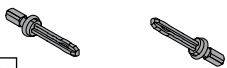
**3**

Art Nr.	Details	P.U
BT60.000D	2 pcs per Runner Set	100

### Synchronisation Rods for TIP-ON BLUMOTION for MOVENTO

**4**



Code	Cut to Suit - 1125 mm	P.U
BT60.1125W	Internal Carcase Width - 241 mm	1/40

### Pull Out Shelf Lock (Optional) See Page 1.84

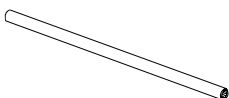

Fixing Method	Art. No.	P.U
Screw On	B295H5700	1

### Pull Out Shelf Lock Synchronisation Shaft (Optional) See Page 1.84



Fixing Method	Art. No.	P.U
Tool Free	BZST1160W	1/40

## Blum MOVENTO with TIP-ON



- Concealed, guided, full extension
- Integrated TIP-ON mechanical opening support system
- Touch to open
- Low opening force to optimise running action
- 4 dimensional tool-free adjustment
- Synchronised smooth running action
- Compatible with side stabilisation for MOVENTO
- Optional TIP-ON Synchronisation for secure triggering even on wider fronts
- Unparalleled running action for the lifetime of the furniture
- 40kg weight carrying capacity 270 - 600 mm
- 60kg weight carrying capacity 450 - 750 mm

### Space Requirement

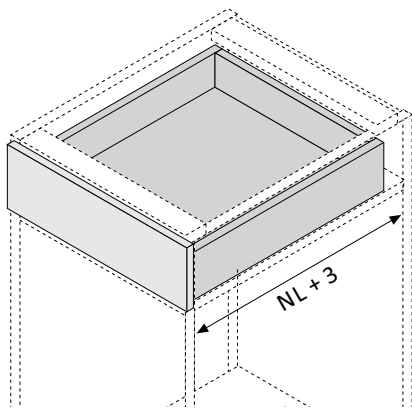

### Components

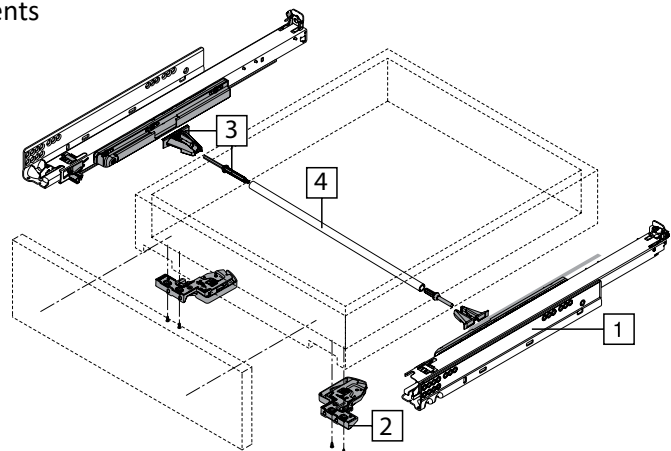

1. Runners, TIP-ON BLUMOTION mechanisms
2. Locking Device
3. Synchronisation adaptors
4. Synchronisation rods

### Height Requirement

\* If runners are fitted prior to cabinet assembly increase height by 1 mm to allow for tolerances

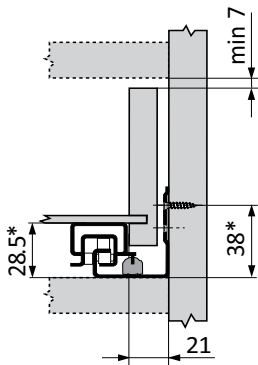

IDW = Internal drawer width  
ICW = Inner cabinet width

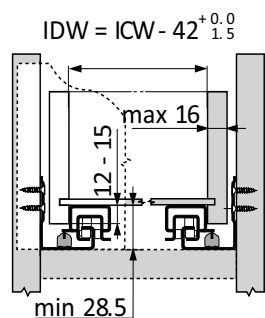

DL = Drawer Length  
NL = Nominal Length

\* + an extra 12 mm if side stabiliser is used

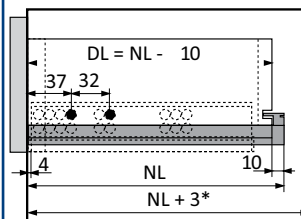

IDL = Inner Drawer Length

DL = Drawer Length  
NL = Nominal Length  
X = Drawer Front  
\* + extra 4 mm TIP-ON  
\* + extra 3 mm with depth adjustment

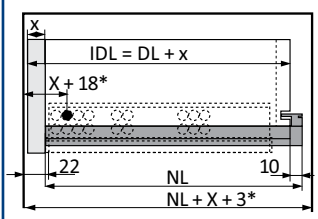

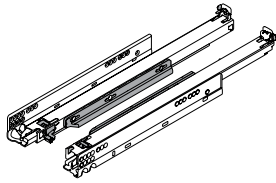

Note: For runner positions and further technical information see Page 1.80

### MOVENTO Runner Set



1

Runner Length	40 kg	60 Kg	P.U
270 mm	B760H270T		6
350 mm	B760H350T		6
400 mm	B760H400T		6
450 mm	B760H450T	B766H450T	6
500 mm	B760H500T	B766H500T	6
550 mm	B760H550T	B766H550T	6
600 mm	B760H600T 	B766H600T	6
650 mm	-	B766H650T	6
700 mm	-	B766H700T 	6
750 mm	-	B766H750T 	6

### MOVENTO Locking Device with Side Adjustment

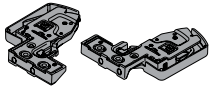

2

Fixing Method	Left Hand	Right Hand	P.U
Screw On	BT517601L	BT517601R	250

### Pinion Set for Synchronisation Rods

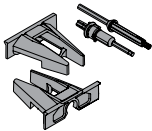

3

Art Nr.	Details	P.U
BT577400	1 Set per Runner Set	100

### Synchronisation Rods for TIP-ON for MOVENTO

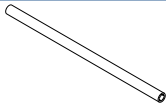

4

Code	Cut to Suit - 1160 mm	P.U
BZST1160W	Internal Carcase Width - 249 mm	1/40

### MOVENTO Side Stabilisation Kit (Optional)



Drawer Length	Art. No.	P.U
≤ 750 mm	BZS7750MU 	10

For cabinet widths ≤ 1400mm for Cutting to size: Internal cabinet width -295 mm  
 Runner length 400 - 750 mm recommended for cabinet widths ≥ 900 mm  
 Runner length 270 - 350 mm recommended for cabinet widths ≥ 600 mm

### Pull Out Shelf Lock (Optional) See Page 1.84



Fixing Method	Art. No.	P.U
Screw On	B295H5700	1

### Pull Out Shelf Lock Synchronisation Shaft (Optional) See Page 1.84

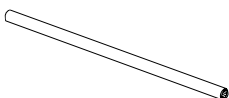

Fixing Method	Art. No.	P.U
Tool Free	BZST1160W	1/40

## Blum MOVENTO with BLUMOTION - Base fixing



- Concealed, guided, full extension
- Integrated BLUMOTION soft close
- Low opening force to optimise running action
- 4 dimensional tool-free adjustment
- Synchronised smooth running action
- Unparalleled running action for the lifetime of the furniture
- 40kg weight carrying capacity
- For Assembly to base panel / shelf

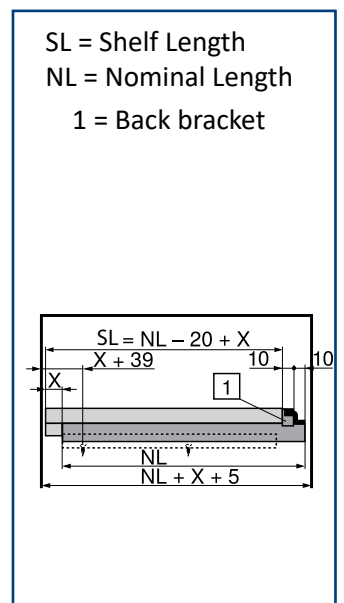
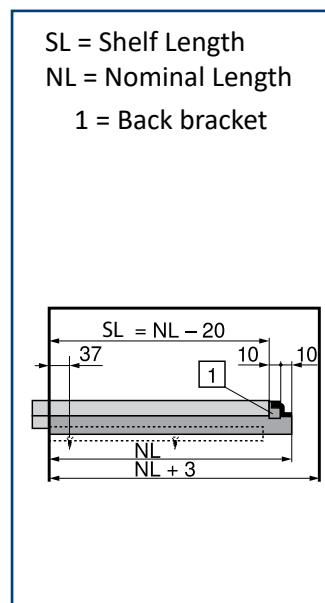
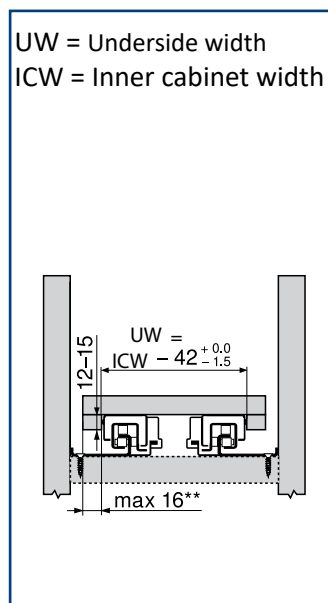
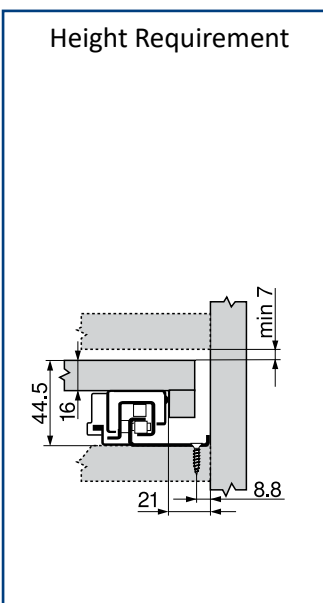
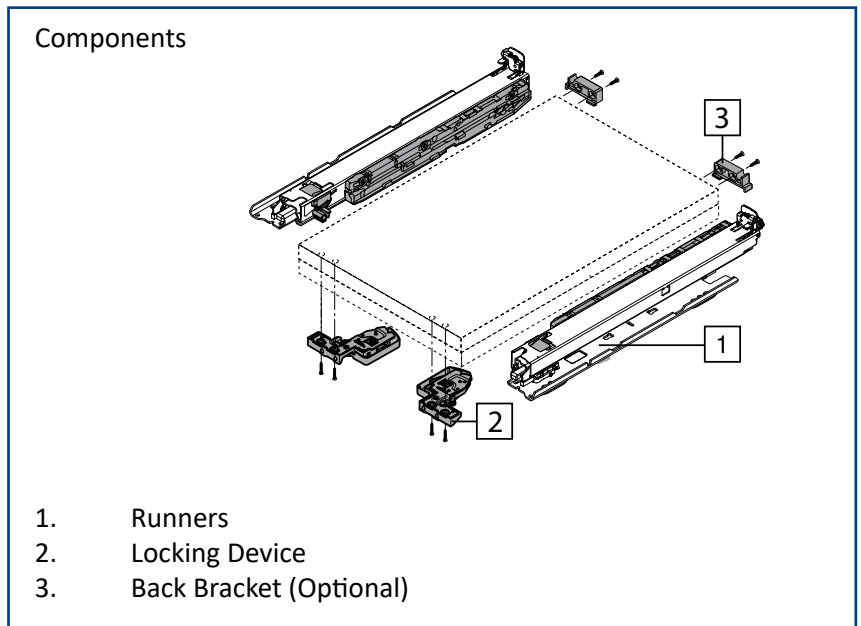
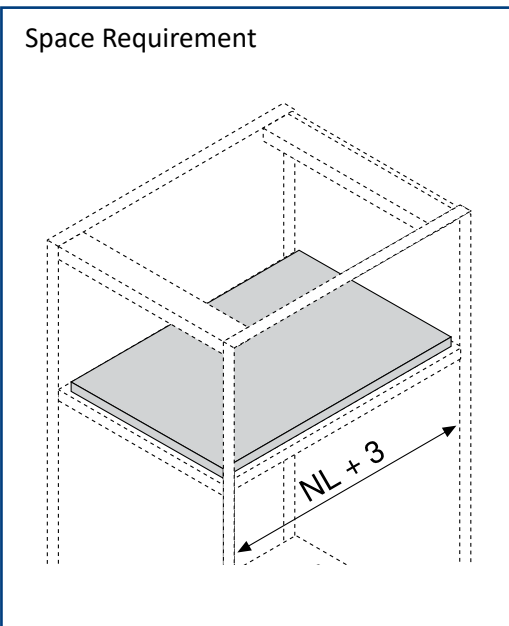





Note: For runner positions and further technical information see Page 1.80

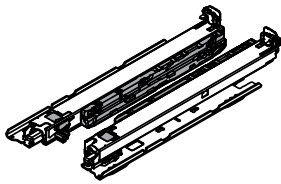

## Blum MOVENTO with BLUMOTION - Base Fixing

### MOVENTO Runner Set



Runner Length	40 kg	P.U
350 mm	B760H350BU 	6
400 mm	B760H400BU 	6
450 mm	B760H450BU 	6
500 mm	B760H500BU 	6

### MOVENTO Locking Device with Side Adjustment

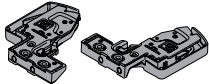

Fixing Method	Left Hand	Right Hand	P.U
Screw On	BT517601L	BT517601R	250

### Back fixing bracket for MOVENTO / TANDEM (Optional)

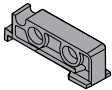

Art. No.	P.U
BT517000.01 	10

For pull out shelves or where no hole is drilled in the back of drawer.  
Used Left and right, reduce the drawer side depth by an additional 10 mm

### Pull Out Shelf Lock (Optional) See Page 1.84



Fixing Method	Art. No.	P.U
Screw On	B295H5700	1

### Pull Out Shelf Lock Synchronisation Shaft (Optional) See Page 1.84

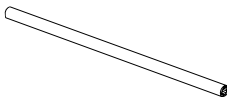

Fixing Method	Art. No.	P.U
Tool Free	BZST1160W	1/40

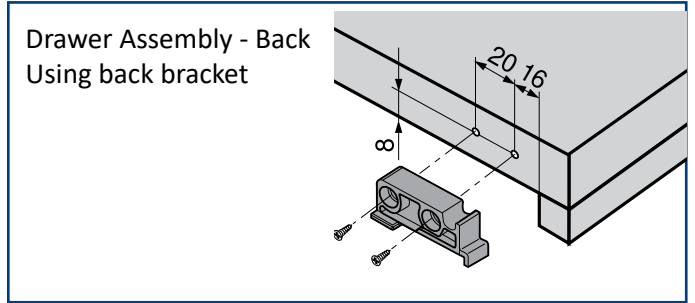
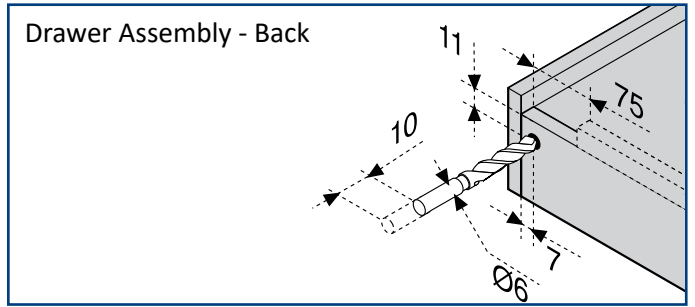
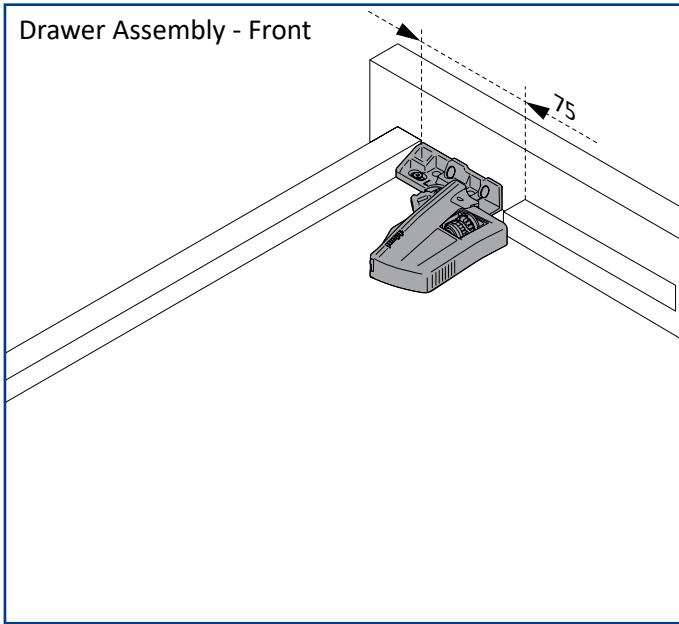

### Locking Device

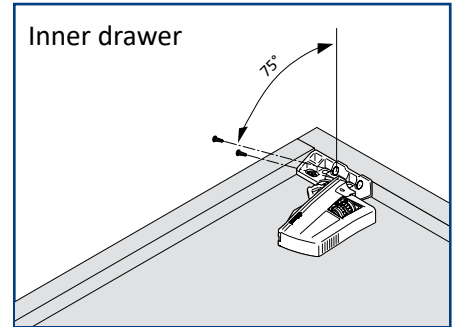
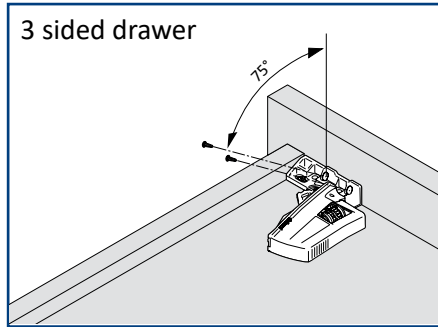
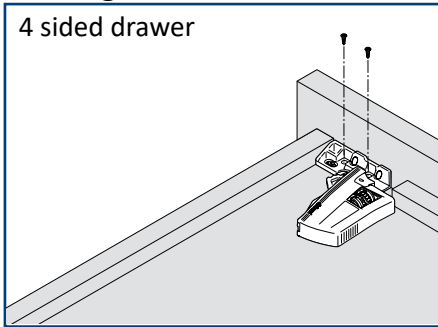

### Adjustment

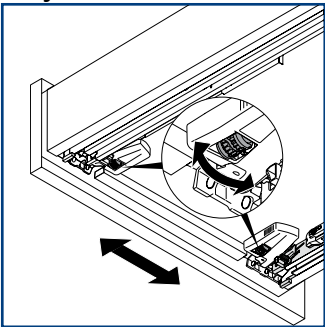

Side adjustment on both sides via locking device  
+/- 1.5 mm

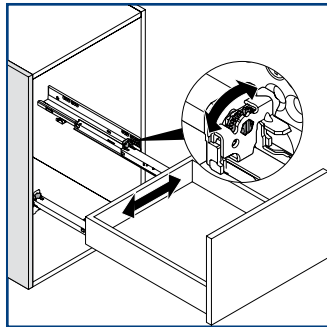

Balance side adjustment via the right back runner

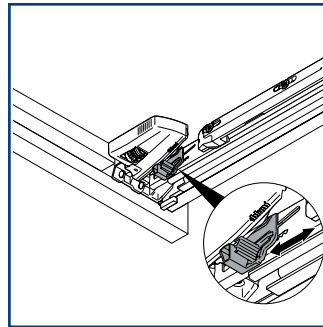

Height adjustment on both sides via locking device  
+3 mm

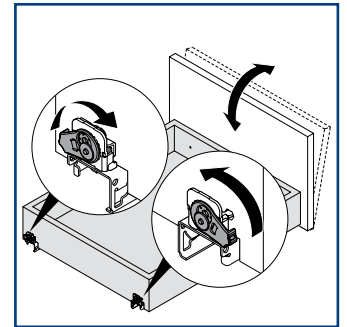

Tilt adjustment on back of runners

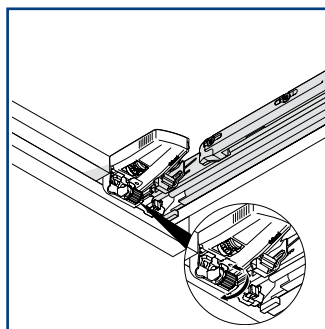

Depth adjustment  
+/- 2 mm for MOVENTO  
with BLUMOTION

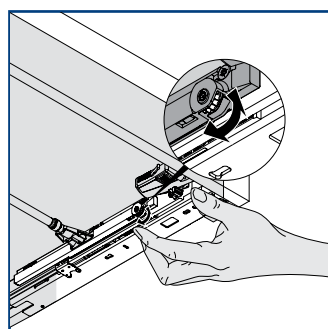

Depth adjustment  
+2/-1 mm for MOVENTO  
with TIP-ON

### 40 kg Cabinet Profile fixing positions

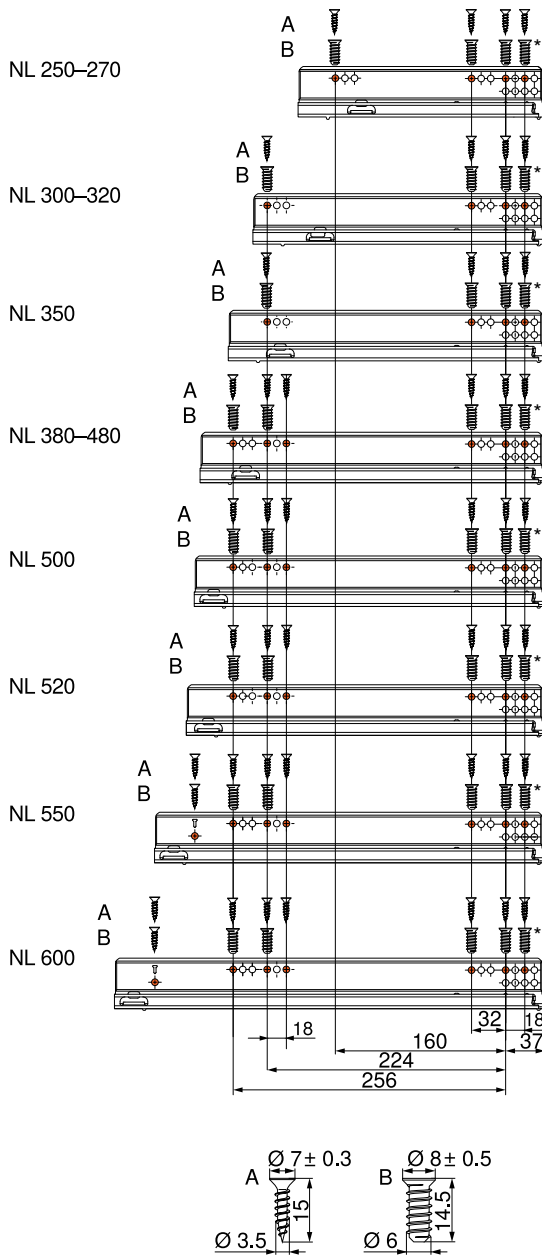

### 60 kg Cabinet Profile fixing positions

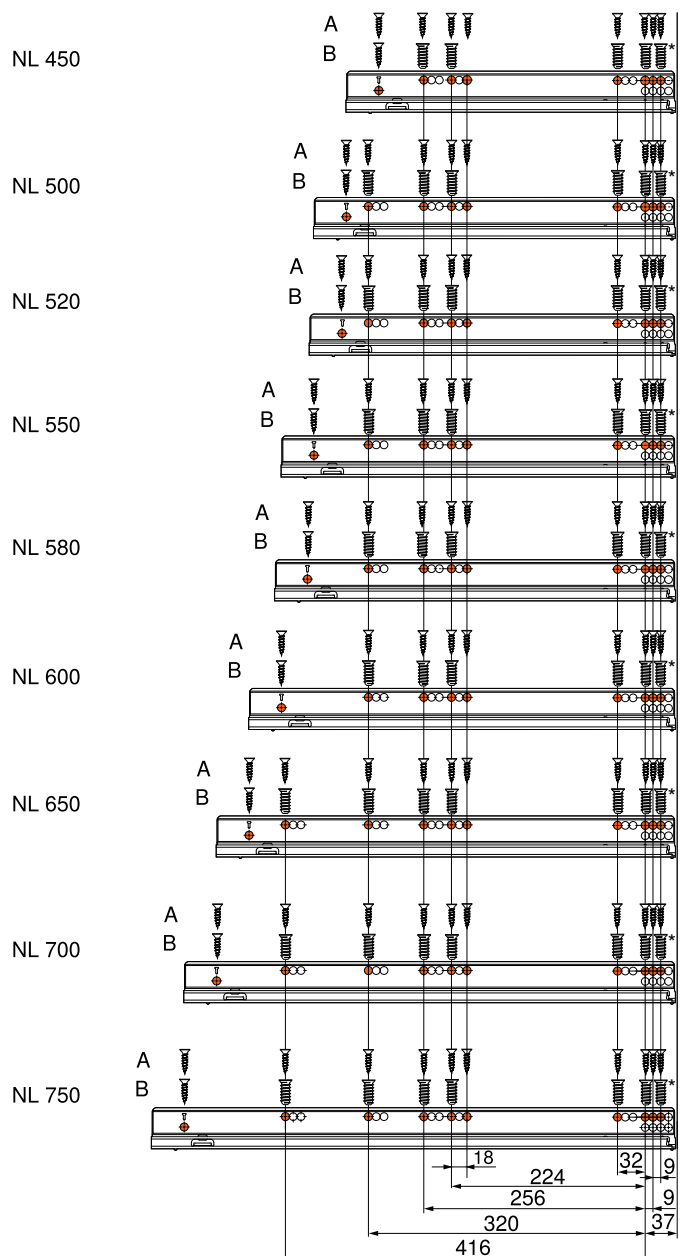

### Runner Positions Base fixing MOVENTO

NL 350–450

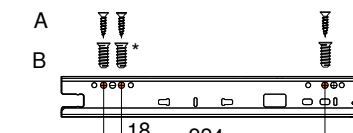

NL 500

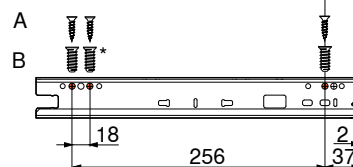

A= Chipboard Screw 4x15mm B= System Screw

### Cabinet Assembly

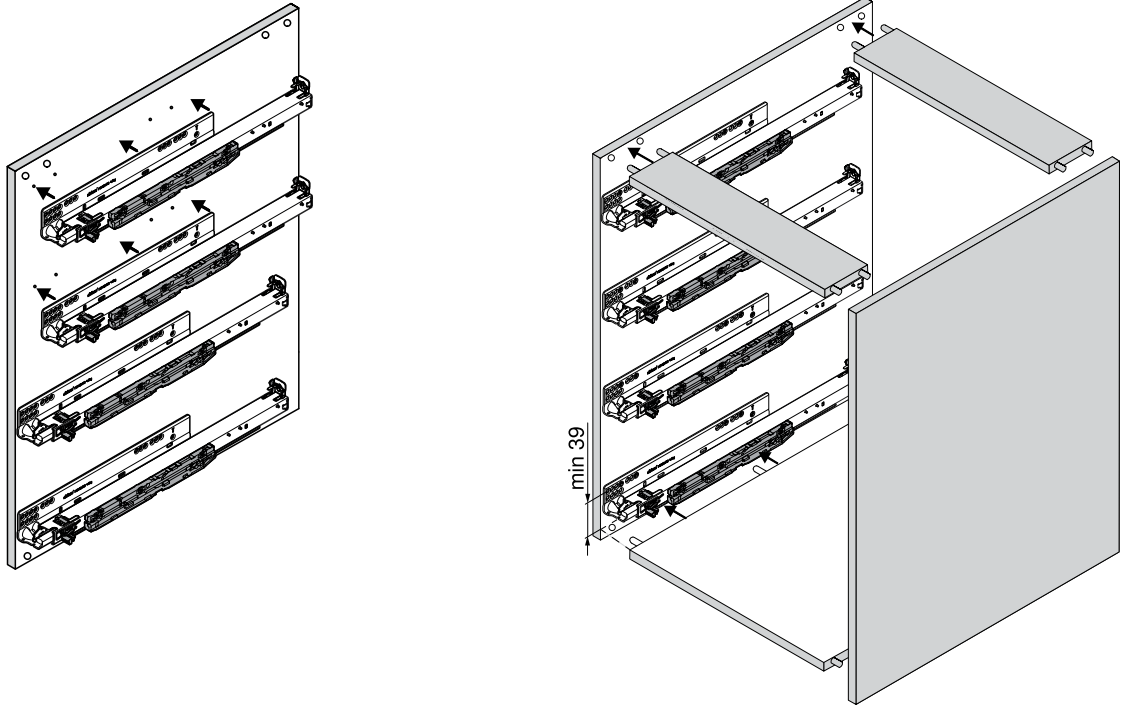

If you install runners before cabinet assembly, the fixing position must be increased by at least 1mm from 38 to at least 39 mm due to tolerances in the runner and cabinet